

# INTEGRATED FREQUENCY INVERTERS

MOTOR POWER 0.37 ... 7.5 KW

EN



<b>CONTENTS</b>	<b>PAGE</b>
Portfolio	3
Industries	4
Technical Features	6
Software KEB Drive & KEB-Drive MU Parameters	8
Options & Dimensions	10

## INTEGRATED FREQUENCY INVERTERS

Frequency inverters expand the functions of three-phase motors. With their help, the universal drive machines can be operated flexibly. Precise starting and stopping, smooth acceleration and braking, as well as operation at different motor speeds are all made possible by the inverter's electronics.

In the version as decentralised units, which are mounted directly on the motor, there are further advantages. Space savings in the control cabinet or easy wiring are just two of them. KEB uses an extensive range of integrated frequency inverters, which seamlessly interlock with the modular system of geared motors and motors.



**HELICAL GEAR UNITS:** the classical gear unit with high power density and a wide range of ratios up to 13,600 Nm

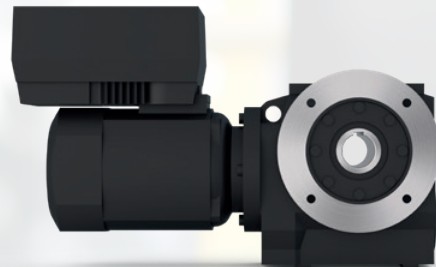

**WORM GEAR UNITS:** the angular gear unit with high ratio up to 1,160 Nm



**DM MOTOR WITH INTEGRATED FREQUENCY INVERTER:**

Motor power 0.37 - 7.5 kW with a wide range of options integrated into the motor modular system

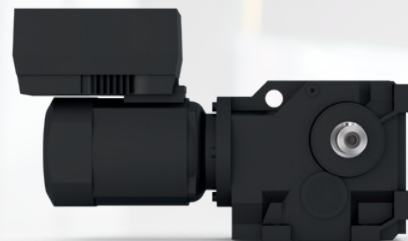

**BEVEL GEAR UNITS:** the angular gear unit with high efficiency up to 12,200 Nm

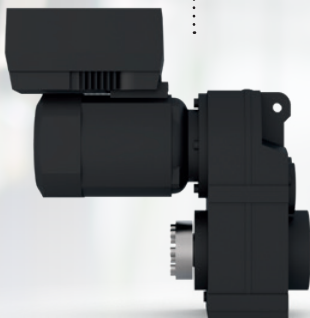

**SHAFT MOUNTED GEAR UNITS:** the gear unit for easy mounting up to 8,900 Nm

## SOLUTIONS FOR MACHINES AND PLANTS



### **INTRALOGISTICS**

Conveying, transporting and lifting for CONTINUOUS AND CYCLIC PROCESSES. Applications with the highest variance and supported in many ways in the KEB portfolio.

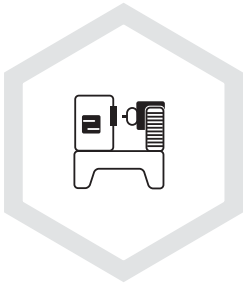

### **METALWORKING**

Metalworking requires stable drives for robust machines and POWERFUL COMPONENTS FOR DYNAMIC movements - as auxiliary unit or main drive. The KEB modular system serves exactly these target areas.



### **PLASTICS TECHNOLOGY**

PRECISION, PERFORMANCE AND QUALITY - the strengths of our systems are particularly evident in plastics machinery, one of KEB's main fields of application.



### **TEXTILE PROCESSING AND FINISHING**

Winders and spools are operated with high speed PROTECTED DRIVES operate in bleaching, dyeing and washing plants with the the full range of options available.



### WOODWORKING

Key applications in woodworking machines are all tasks of edge and surface processing, drilling and milling technology, assembly systems and the COMPLETE MACHINING AND FINISHING of solid wood.



### FOOD INDUSTRY

Flexible drives for use in food processing perform a wide variety of tasks. With durable corrosion protection and increased degree of protection, drives with INTEGRATED FREQUENCY INVERTERS are used.



### PACKAGING INDUSTRY

Packaging machines have to cope with a wide range of tasks. Each with the highest efficiency and high dynamics. These processes are made possible WITH INDIVIDUAL DRIVES and integrated frequency inverters.



## TECHNICAL FEATURES

Asynchronous geared motors are operated on the mains with constant frequency at constant speeds. For some of our customer applications, this is all that is needed. For other applications, however, more flexibility in the speed range is required.

Frequency inverters are the right solution for this. They can be used to change frequencies and voltages. Our asynchronous geared motors can then be operated at variable speeds. With frequency inverters, processes can be controlled more precisely, the geared motors can be started and stopped more smoothly and thus mechanical loads can be reduced.

In addition to the previous range of central drive controllers in the KEB product portfolio, decentralised solutions are now also available. The frequency inverter of the MU series has become an integral part of our asynchronous geared motor - in other words, all in one. Your advantage: compact design, easier installation and high performance.

In well-known manner, all asynchronous versions of the geared motors from the modular system can be combined with the different integrated frequency inverters. Depending on the performance requirements, the application and the customer's needs, there is always the right solution.



### HIGHLIGHTS:

- Decentralised inverter integrated in geared motor modular system
- 0.37kW - 7.5kW
- High IP protection
- Inverter directly in the field → Short cable lengths
- Optional: Fieldbus connection, brake handling, etc.

KEB offers integrated frequency inverters in ten sizes for mains voltages of 230 & 400 V. Thanks to the extensive motor portfolio and the combination with compact inverters, powerful drive solutions are created. The motors can be dimensioned for different operating points (87, 100 & 120Hz) in a space-saving and efficient manner. This is another approach to configure individual drives.

The inverters are protected in a separate housing for use in the field. Motors / geared motors with integrated frequency inverters can take over control and monitoring functions in addition to the drive task and can be integrated into centrally controlled systems.

### GENERAL FEATURES:

- Mounting directly on the motor or by wall mounting close to the motor
- Standard switching frequency: 8 kHz
- With motor mounting and standard switching frequency: EMC limit class C2 according to DIN EN 61800-3
- Service interface for commissioning and parameter setting with PC software
- Ambient temperature: max. 40°C

### OPERATING MODES:

- Frequency control mode
- PID process controller
- Fixed frequencies

### PROTECTION FUNCTIONS:

- Blocking detection
- $I^2t$  evaluation
- Evaluation motor protection TW or TS

MOTORS Performance up to $P_{mot}$ (kW)	Frequency inverter											
	1x 230V			3x400V								
	Type	$I_n$	$I_{in}$	Type	$I_n$	$I_{in}$	Type	$I_n$	$I_{in}$	Type	$I_n$	$I_{in}$
0.37	MUM05	2.3	4.5									
0.55	MUM06	3.2	5.6	MUA06	1.7	1.4						
0.75	MUM07	3.9	6.9	MUA07	2.3	1.9						
1.1	MUM08	5.2	9.2	MUA08	3.1	2.6						
1.5	MUM09	7	13.2	MUA09	4	3.3						
2.2							MUB10	5.6	4.6			
3							MUB11	7.5	6.2			
4							MUB12	9.5	7.9			
5.5										MUC13	13	10.8
7.5										MUC14	18	14.8

$P_{mot}$  [kW] Recommended motor power

$U_n$  Mains voltage

$I_n$  [A] Output current

$I_{in}$  [A] Input current

# SOFTWARE KEB DRIVE & KEB-DRIVE MU PARAMETERS

FULL DESCRIPTION

FAST PARAMETERING

CONVENIENT CHOICE

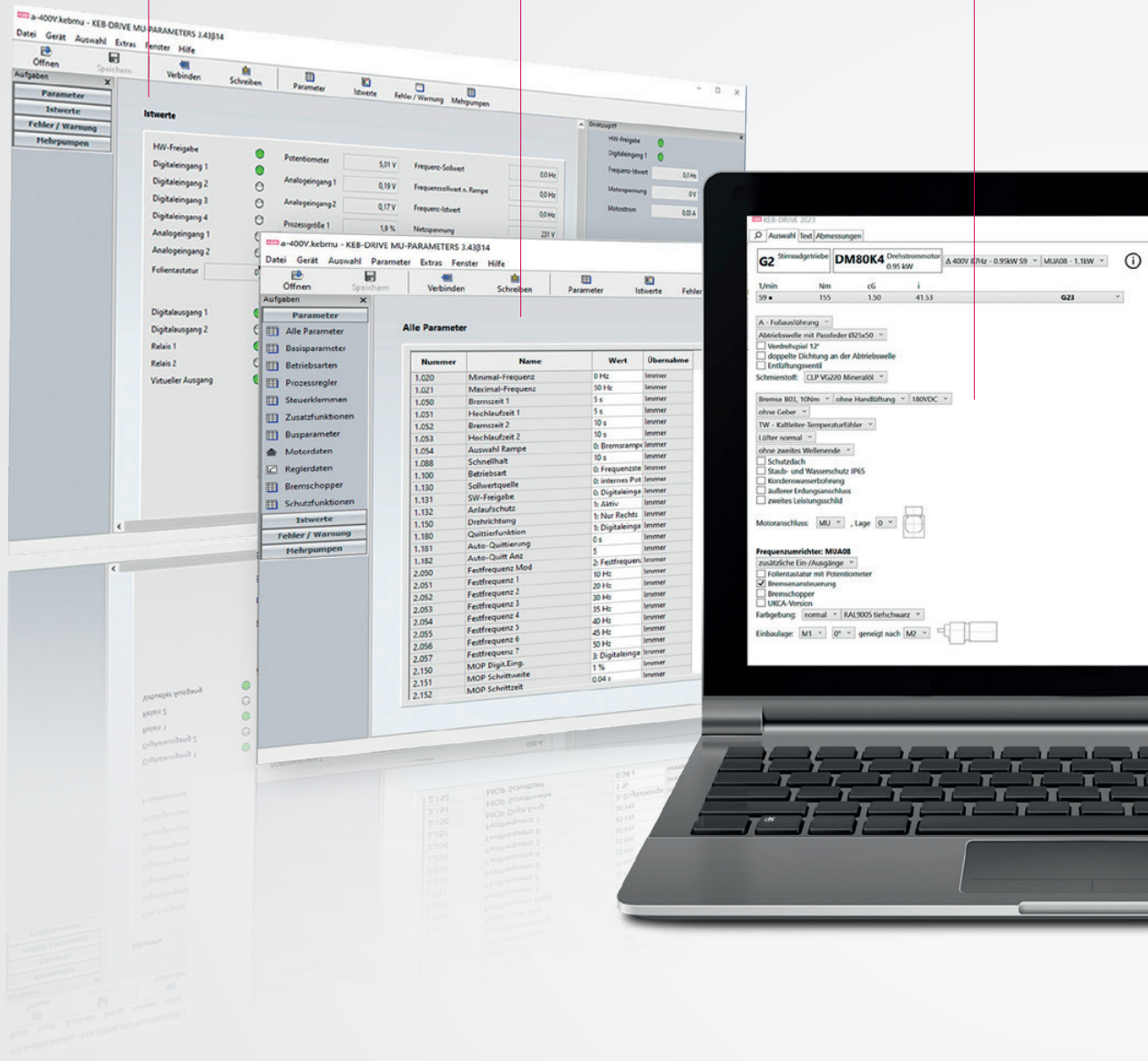

Put together the right drive package quickly and make the right selection from the prepared options. The KEB DRIVE configurator offers this and much more:

- Detailed product descriptions with data tables
- 2D dimension drawings and 3D models
- direct export functions, e.g. into the ERP system

With the programme "KEB-DRIVE MU-PARAMETERS" it is possible to access and parameterise the integrated frequency inverters MU.



## FULL DESCRIPTION

## SCALE AND 3D MODEL



STEP: Solid model in STEP format

RTF: Saves the product dimension sheet in RTF format to the clipboard



## KEB DRIVE

- Quick configuration and selection of KEB gear unit and motors
- Precise description and data IMMEDIATELY available
- Geometric data 2D and 3D can be accessed directly
- System creation with further KEB components

Download product selection programme for KEB gears & motors: [www.keb-drive.de](http://www.keb-drive.de)

## OPTIONS & DIMENSIONS

EQUIPMENT	MUM	MUA	MUB	MUC
Supply voltage from	1 x 100VAC	3 x 200VAC	3 x 200VAC	3 x 200VAC
Supply voltage up to	1 x 230VAC	3 x 480VAC	3 x 480VAC	3 x 480VAC
<b>I/O</b>				
Digital IN	2x	2x	2x	2x
Digital Out	2x	2x	2x	2x
Analog IN	1x	1x	1x	1x
Supply				
10VDC	x	x	x	x
24VDC	x	x	x	x
<b>Options</b>				
Membrane keypad / potentiometer	x	x	x	x
Brake control	x	x	x	x
Additional I/O's		x	x	x
Brake chopper / brake resistor		x	x	x
STO		x	x	x
<b>Fieldbus connection</b>				
EtherCAT		x	x	x
ProfiNET		x	x	x
Profibus		x	x	x

### ACCESSORIES:

- Programming and diagnostic cable for PC
- Bluetooth stick

### PARAMETERISATION SOFTWARE

- KEB-Drive MU-Parameters

INVERTER / DIMENSION IN MM	L	B	H
MUM	233	153	128
MUA	233	153	128
MUB	270	189	145
MUC	307	233	186

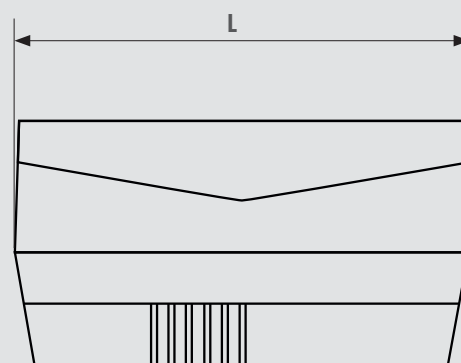
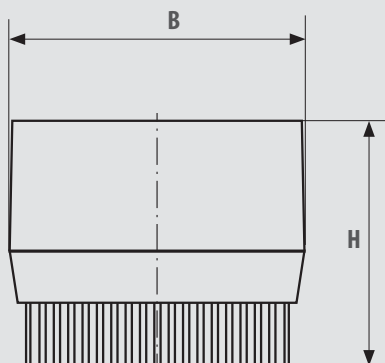

## KEB DRIVE TECHNOLOGY

### DO YOU HAVE ANY QUESTIONS OR SUGGESTIONS?

THE COMPETENCE CENTER FOR GEARED MOTORS AND SERVOMOTORS IS THE CENTRAL CONTACT FOR THE INTEGRATED FREQUENCY INVERTERS OF THE MU SERIES

#### Germany | **Geared motor plant**

KEB Antriebstechnik GmbH

Wildbacher Straße 5 08289 Schneeberg Deutschland

Tel: +49 3772 67-0 Fax: +49 3772 67-281

E-Mail: [info@keb-drive.de](mailto:info@keb-drive.de)



**MORE INFO ABOUT THE KEB PORTFOLIO:**

<https://www.keb-automation.com>



**CronaTech Drives AB**

[www.cronatech.se](http://www.cronatech.se)

+46 31 961520

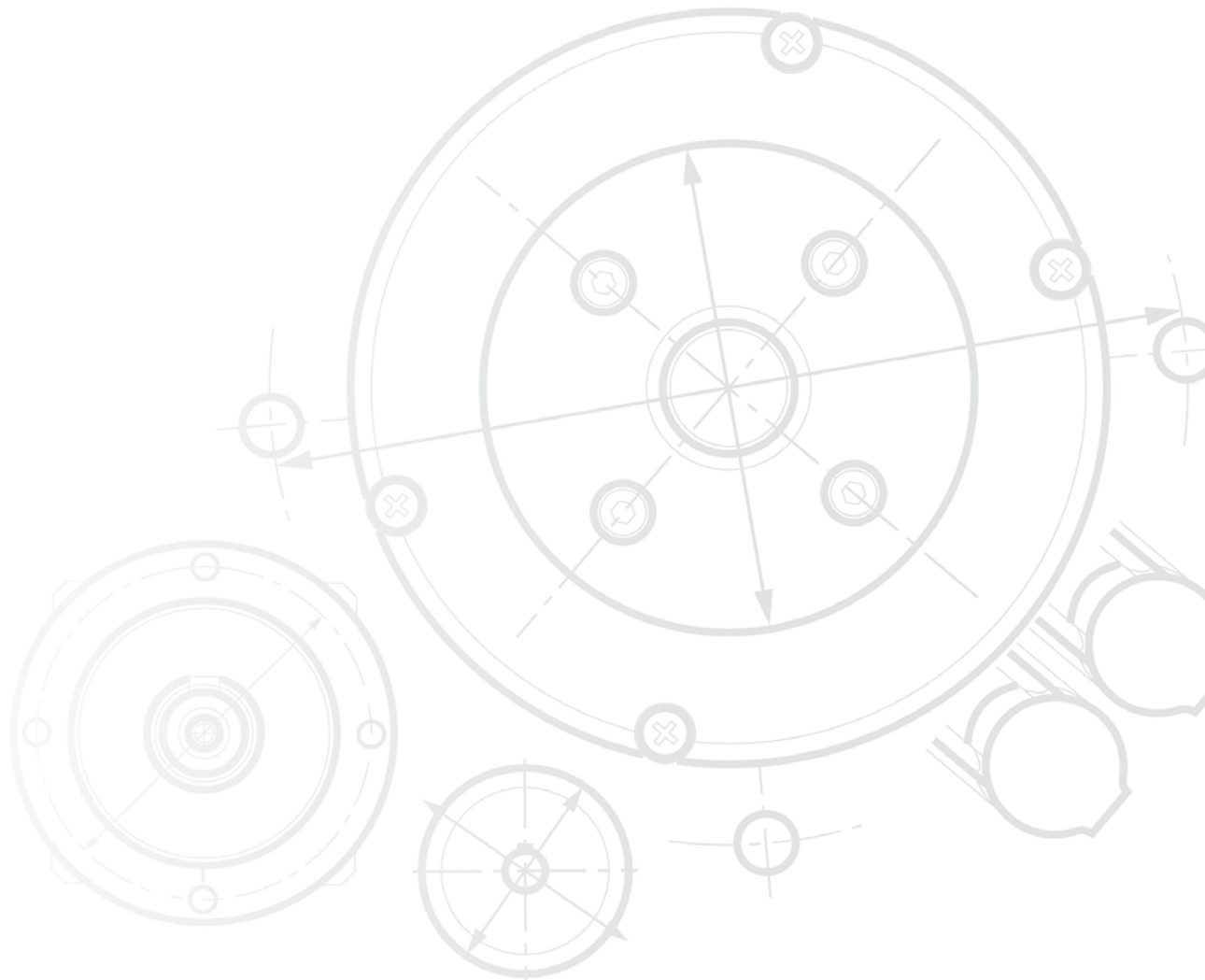

**Automation with Drive**

**keb-automation.com**

KEB Antriebstechnik GmbH Wildbacher Straße 5 08289 Schneeberg Tel. +49 3772 67-0 E-Mail: [info@keb-drive.de](mailto:info@keb-drive.de)